

Air Handling Unit

Roof mounted Air Handling Unit - GRTU 3800+

The GRTU-3800+ roof mounted unit is an effective air handling unit with heat recovery for simple and easy mounting on the roof of eg. a garage, workshop or production facility.

The wide range of accessories for the GRTU makes it a good match for a variety of ventilation applications where high heat recovery and low energy consumption is required.

GRTU 3800+ is based on a rotating heat exchanger, which recovers up to 84% of the heat from the extracted air. The air inlet and outlet is integrated in the sides of the unit and effective filters ensure that the high efficiency on the heat exchanger is maintained.

The EC fans fitted with direct drive B-impellers comply with the standard of energy effectiveness class IE3 (applicable from 2015). The fans are 100% continuously variable, so the airflow is easily balanced for the required task. The entire construction is galvanized and sealed in the joints. Modular construction with rail systems makes for easy inspection / replacement of components, and gives the unit flexibility in regards to accessories and installation. GRTU 3800+ can be mounted on both flat and sloping roofs. In both cases only one roof base is required. The unit's mounting frame makes it easy to place in the roof base. GRTU 3800+ can also be mounted indoors where this is preferred, and which is to be addressed when ordering. Extraction and supply air ducts are placed at the bottom of the unit and fixed channel connections or diffuser solution can be selected. Geovent generally recommends the solution with channels which provides better air distribution.



Installation example for GRTU 3800+

The GRTU 3800+ has low energy consumption and a highly effective impeller.

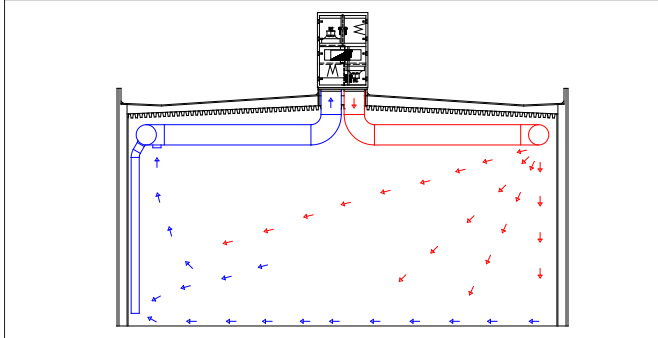

The GRTU 3800+ comes complete with control panel and must be connected to 3x400V. By default, the automatic are set to a fixed airflow (pressure control) and with the built-in day / week timer the unit is programmed to only ventilate during the periods that are needed.

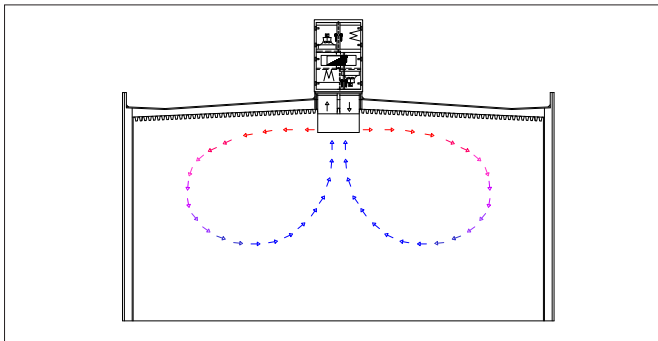

For instance, in auto repair shops, where extraction of heavier gases and vapors can occur, the diffuser solution is not recommended. Instead it is recommended that 60% of the contaminated exhaust air is removed by the floor and 40% at the ceiling. Supply air with injector bags, nozzles, grids or anemostats.

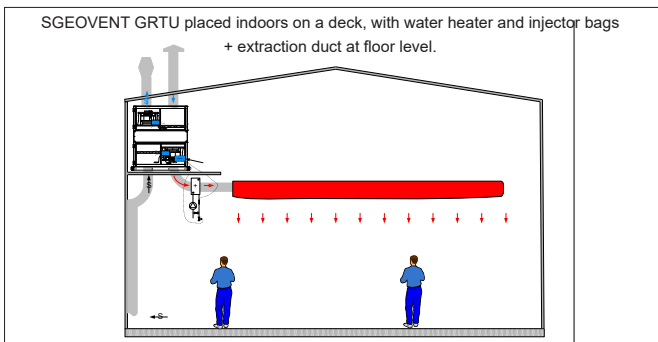

Indoor placed GRTU located at deck, in special execution, incl. circular connections in the top for air inlet/outlet. Example shows solution with supply air bags and extraction at floor level. Furthermore, a heater is mounted.

Pressure loss for GRTU 3800+

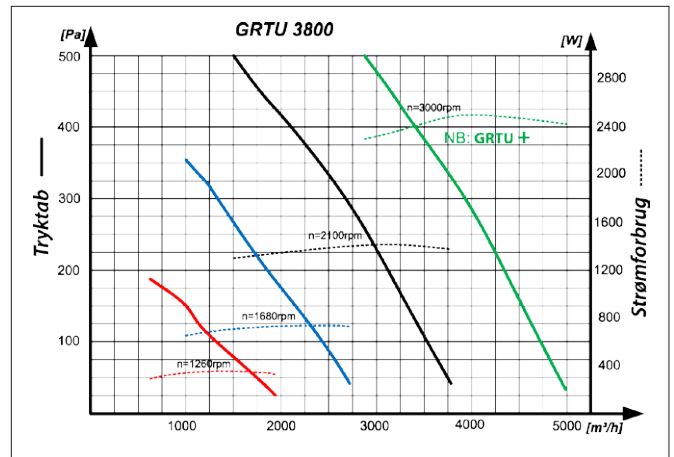

The fan diagram displays the available pressure for duct system. The outer curve shows max air flow for the GRTU 3800+ + (order number: 02-602A). GRTU 3800+ + is used in situations, where there is a need for higher available pressure.

Noise data from fan 2100rpm (max).

The units own isolation is not included in the shown data

Hz	63	125	250	500	1000	2000	4000	8000	Samlet
Extraction side	43	55	64	64	61	59	56	56	70 dB(A)
Pressure side	45	57	66	67	63	61	58	58	72 dB(A)

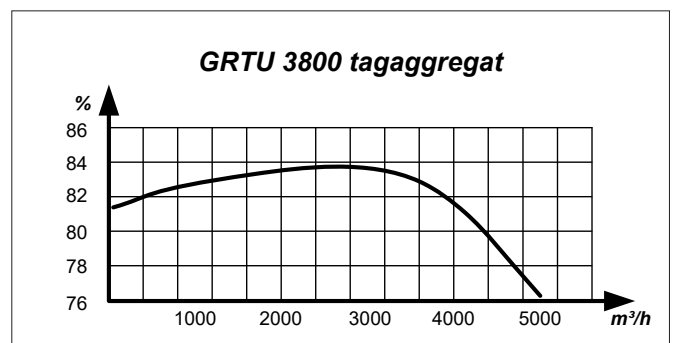

Curve showing the efficiency of the rotor at different airflows

Technical data for GRTU 3800+

Supply power 3x400V, 50Hz

Cabinet: Galvanized sheet metal, 50 mm isolation.

Fans: 2 stk. German produced EC-blue with plastic impeller. 1,4kW, 50Hz, 3x400V, 2,4-1,9A, k-factor 172.

3800++ German produced EC-blue with aluminium impeller. 2,2kW, 50Hz, 3x400V, 4,0-3,2A, k-factor 95.

Filter: The filter as standard is F7.

Rotor: Alu coil with 1,6mm wave height. Galvanized steel frame for horizontal mounting. Motor: 3x400V 0,04kw.

Weight: 400 kg.

Control: Master automatics cabinet is placed inside the unit
3x400V 50 Hz supply



Controls for GRTU 3800+

General:

The GRTU 3800+ consists of 3 main control elements. Main control panel with master controller, fan control and filter guard (2 pcs.), and hand-held terminal for programming and monitoring. Everything is internally wired and ready for use (excl. sensors outside the unit, which must be installed at site).

The controller maintains the preset airflow and regulates the fan continuously. The controller features a day-/week program and gives alarm in case of malfunction and filter change. The integrated controller also handles (optional) reheating and recirculation components.

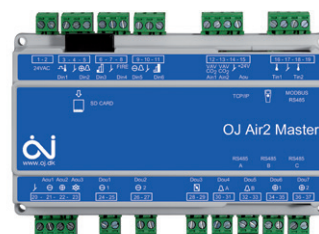

Master controller:

- User-friendly, flexible and gives good overview
- Web server access on 3 individual levels
- Provides lowest possible energy consumption and optimum reliability



Fan IO:

- Input and output module with dual pressure transmitter
- Monitors filters and ensure correct fan flow

Hand terminal:

- Easy to operate for the end user, but can also be used by the installer
- Informative display, that ensures minimal time consumption, high quality and low life cycle costs.

Roof mounted Air Handling Unit

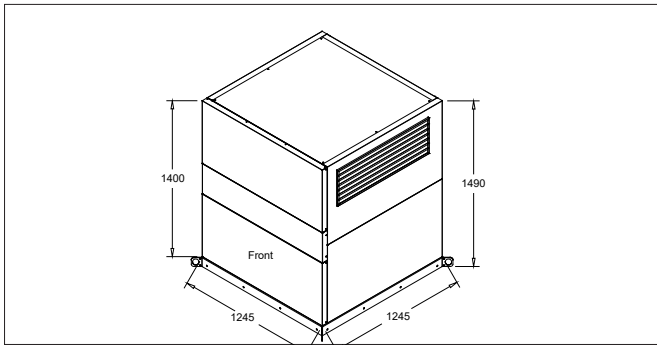
Measures for GRTU 3800+

Measures (Shown without rain cover on inlet/outlet)

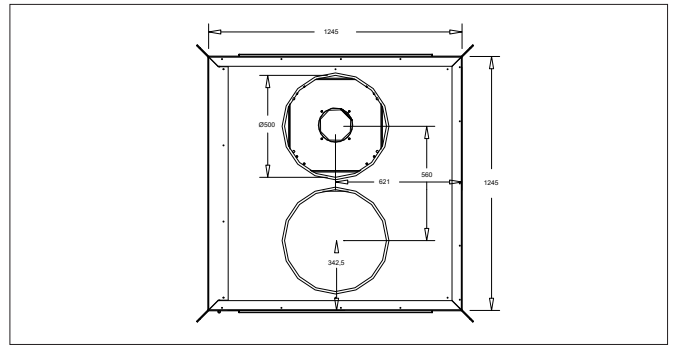

GRTU measures, below.

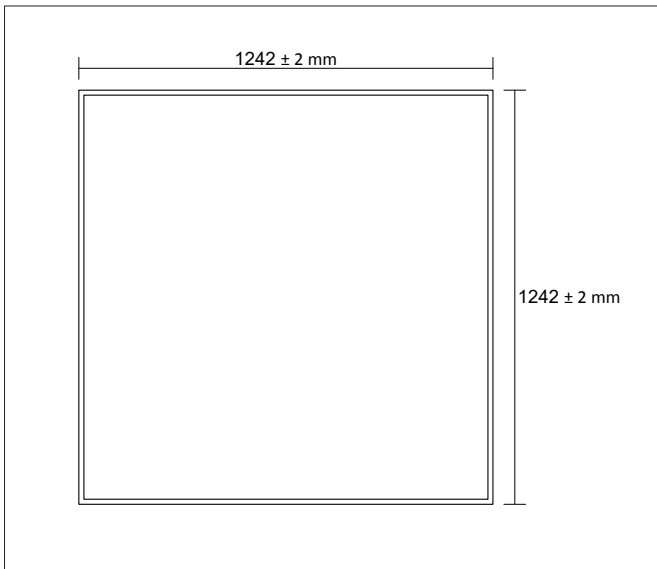
Measures for mounting base

Outer measures mounting base



Example of base on sloping roof

Accessories for GRTU 3800+

Art.no: 02-703

Shut-off damper incl. motor.
Used in both inlet / outlet
as well as recirculation
damper



Art.no: 02-761

Extension channel
800 x 800 x 500



Art.no: 02-762

Extension channel
800 x 800 x 1000



Art.no: 02-710

Motor for damper,
LMC 24 A



Art.no: 02-712

2 way valve R210 + motor
TR24 SR
Used for 10KW water
heater



Art.no: 02-211

Water heater
10 KW water 70/40.
Used when only venting.
For mounting on channel..

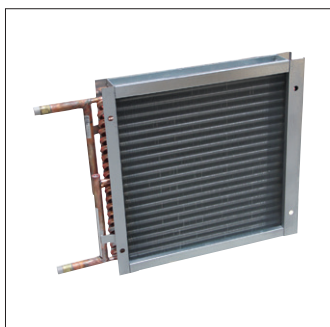

Art.no: 02-714

2 way valve R212 + motor
TR24SR
Used for 25KW water
heater



Art.no: 02-713

Water heater
25 KW water 70/40.
Used for heating /
re-circulation.
For mounting on channel

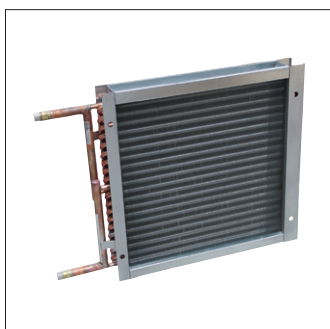

Art.no: 02-717

Room sensor (used when
heating)

Art.no: 02-704

Frost sensor

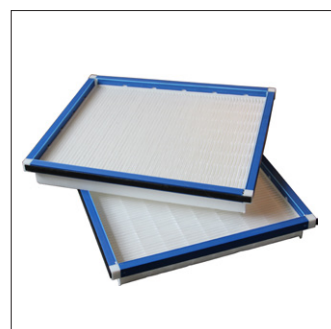

Art.no: 02-715

Diffuser kit
Consists of a transition
piece for mounting on the
GRTU, Flex hose \varnothing 500
incl. hose clamps & diffuser
mounted underneath
800 x 800 square channel



Art.no: 02-717

Cassette filter F7
The kit consist of 2 filters
+ adaption pcs. for each
airflow

Art.no: 02-716

Plain filter F5
(Standard)

Roof mounted Air Handling Unit

TYPE 1

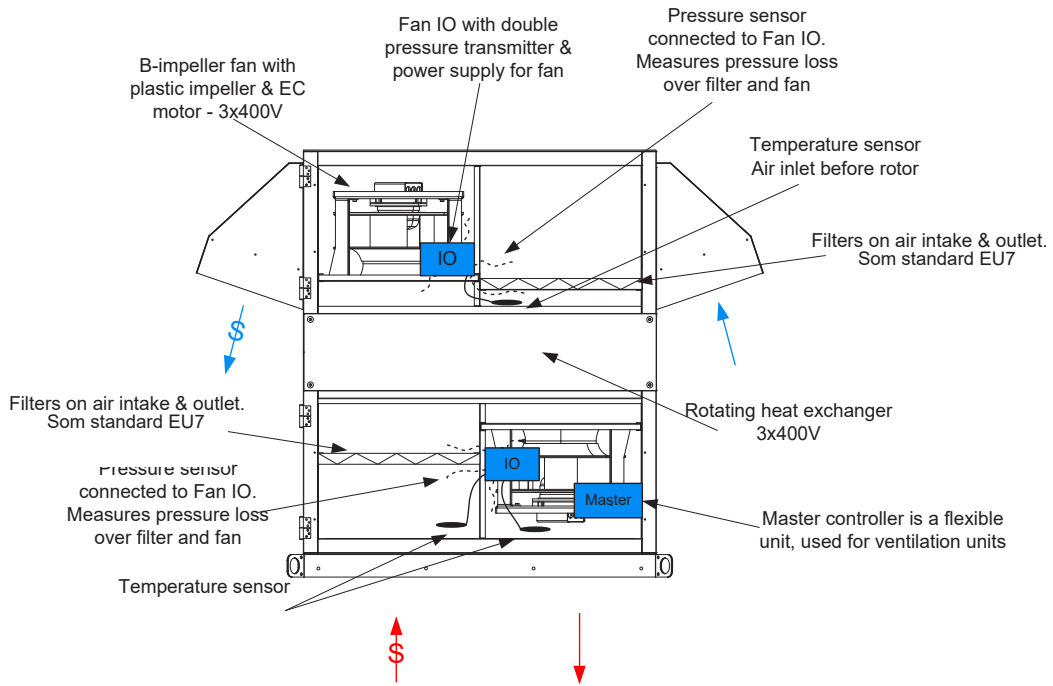

TYPE 2 with water heater

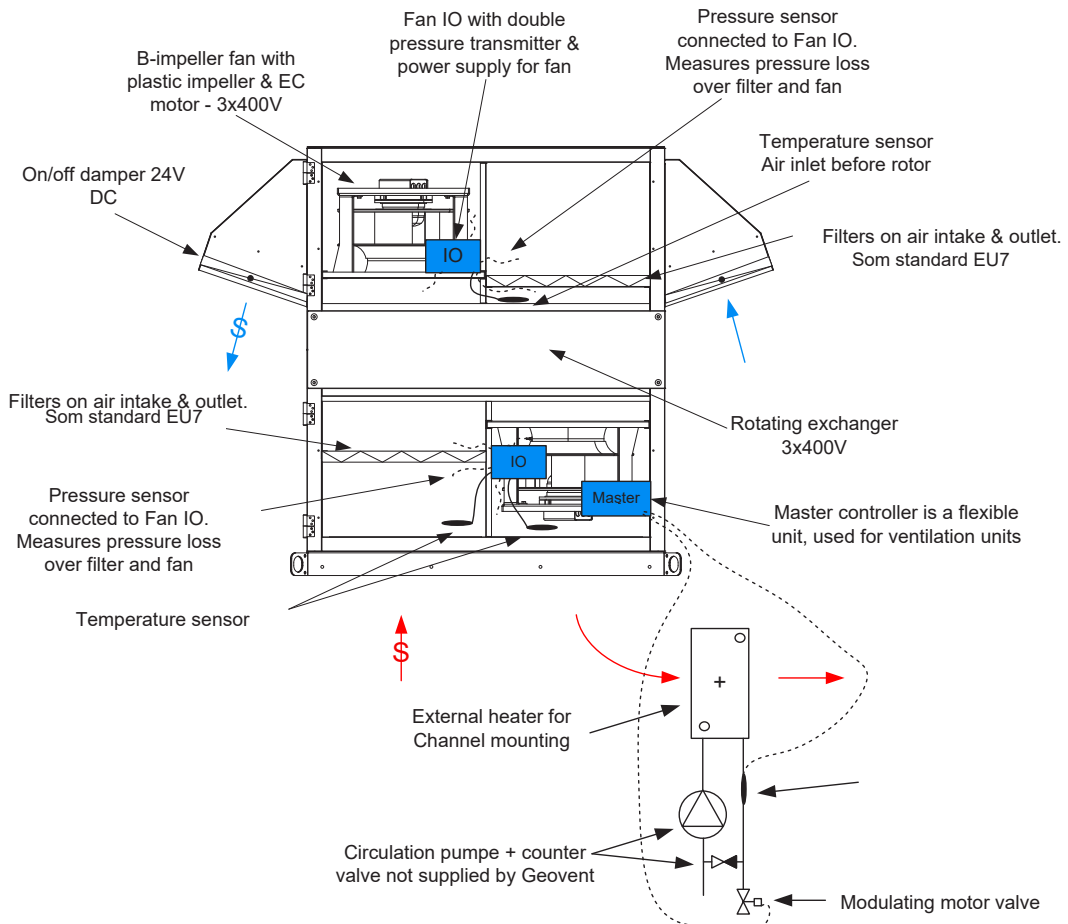

Roof mounted Air Handling Unit

TYPE 3 for recirculation & water heater

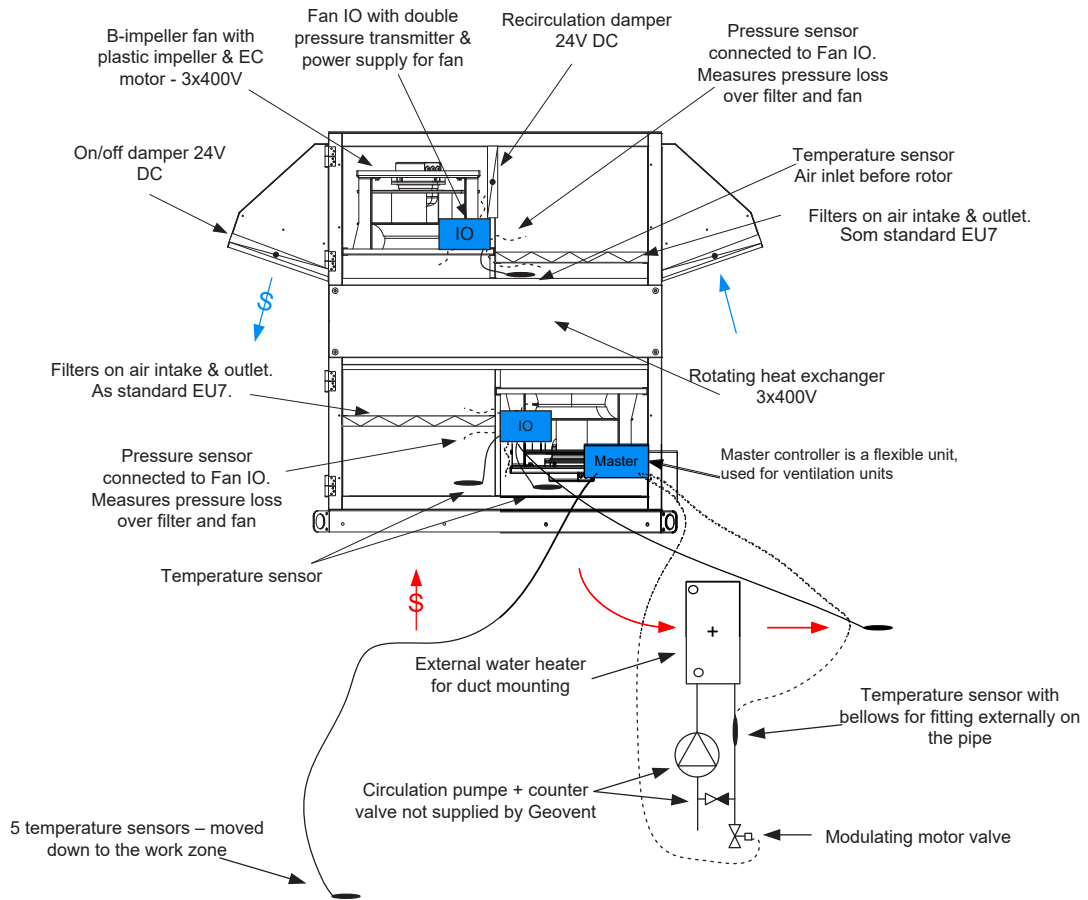

SGEOVENT GRTU placed out doors on the roof, with water heater and injector bag, and extraction outlet by the floor.

