

GEOVENT



GFX filter - ATEX

Geovent GFX filter is the complete ATEX-filter option when you want the exhaust air cleaned effectively.

GFX filters the exhaust air by up to 99.99%.

The filter is cleaned automatically by using shot valves with by compressed air.

The filter applies to a wide range of industries, primarily in industry, which develops explosive dust.

The filter can handle airflows up to 7200 m³/h and if needed connected in parallel. The filter is supplied complete with ATEX control, explosion membrane, spark proof filter cartridges, ATEX shot valves, full ATEX documentation and a collection bucket.

Geo Filter GFX is made of galvanized thin plate.

The design of the filter does not allow outdoor location because of the risk of condensation. Explosion membrane KST value is as standard 250. NB: Both KST & P Max must be abandoned.

GFX filter is also available in a special version for gas applications.



Geovent GFX filter approved for Category 1, 2 and 3 (dust), by which it can be used for dust applications such as aluminum dust, magnesium and flour etc. in zone 20, 21 or 22.

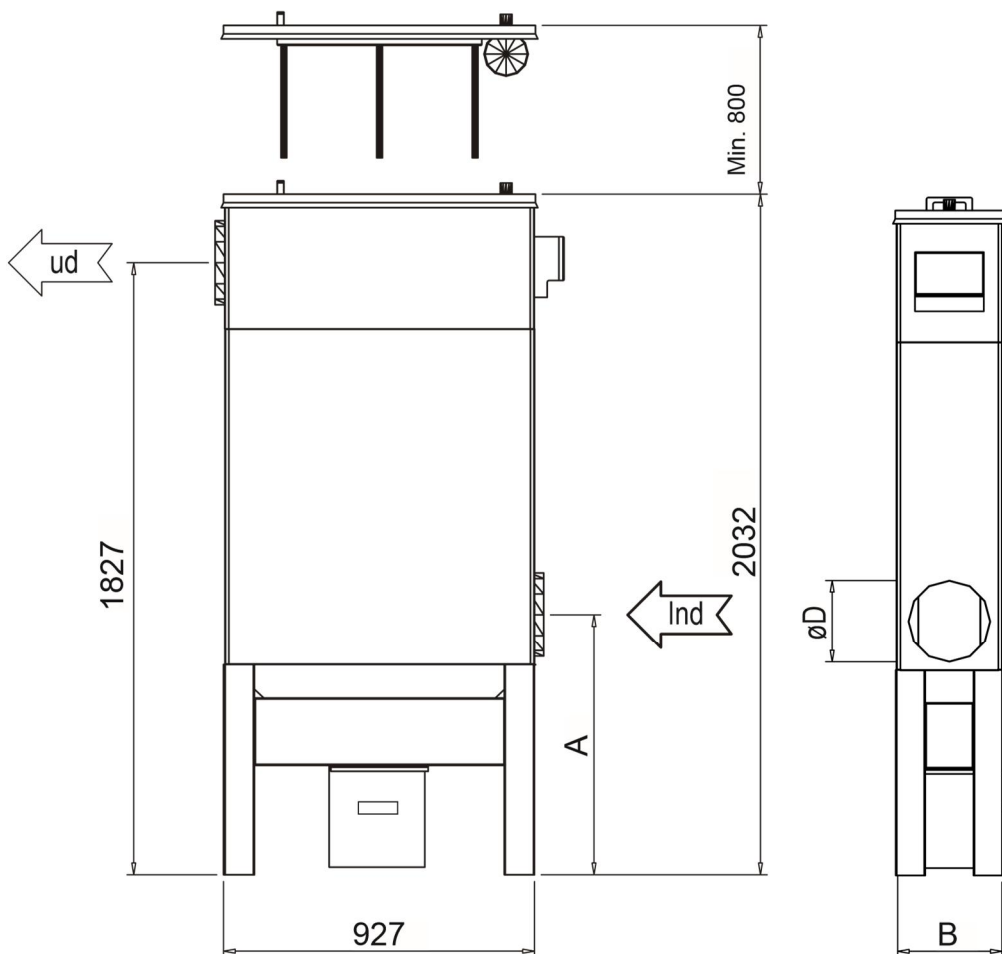

This illustration above shows the standard layout and measures.

Art no.	Model	Dimension (mm)		ØD	Outlet	Height	Weight kg	Max. Air flow
		A	B					
16-400	GFX 3-1	775	325	ø250np	1x250np	Min. 800	90	1800 m ³ /h
16-401	GFX 6-2	808	625	ø315np	1x315np	Min. 800	135	3600 m ³ /h
16-402	GFX 9-3	850	925	ø400np	2x315np	Min. 800	180	5400 m ³ /h
16-403	GFX 12-4	900	1225	ø500np	3x315np	Min. 800	225	7200 m ³ /h



Standard GFX 3-1, GFX 6-2 & GFX 9-3:

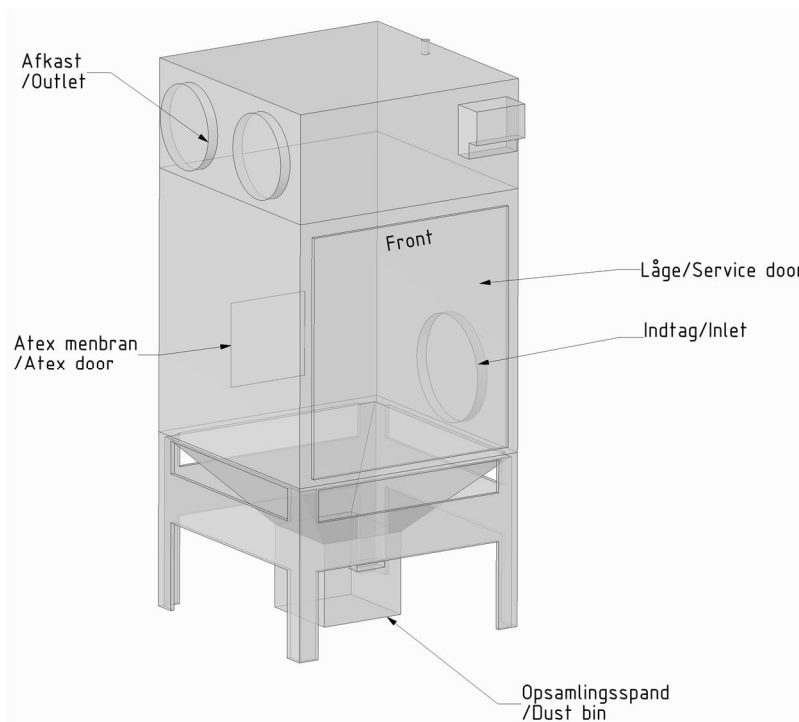

Standard GFX 12-4:

