

Extraction arm

ASA HV50 and MINI HV50 Extraction arm

ASA-HV50 extraction arm for high vacuum system - suitable for welding smoke, grinding dust and vapors, etc. Here, the operator has easy positioning, ergonomics and efficiency. The hose is mounted externally on the support arm, which can easily be placed in any desired position. The arm is made up of 3 joints and 2 joints. Available in lengths of 2.0 m, 3.0 m and 4.0 m. 100-200 m³/h

Wall bracket: Powder coated yellow RAL1007 steel bracket. The console's swivel joint can turn 270°.

Funnel: Silencer special funnel for HVU extraction. The funnel is provided with an integrated griff and can be rotated in many positions. The funnel is powder coated in RAL 7015 and 1007.

Hose: Black GeoFlex High. Temperature from -40°C to +60°C. Arms and friction joint: 25x25 mm aluminum tube, connected via joint with friction discs and spring discs. Inner reinforcement arm is made of 35x35 mm aluminum tube and fitted with gas damper.

Capacity: Up to 2.000 m³/h, which makes it suitable for all types of welding and fumes from glue that require large volumes of air.

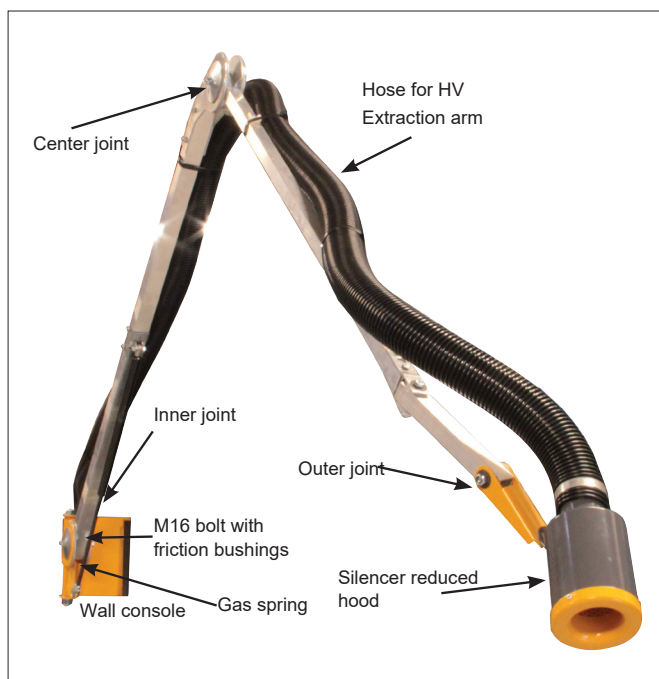

Ordering table

Art. No.	Description
74-480	ASA HV50 Extraction arm 2 m.
74-481	ASA HV50 Extraction arm 3 m.
74-482	ASA HV50 Extraction arm 4 m.
74-483	MINI HV50 Extraction arm 1 m.
74-484	MINI HV50 Extraction arm 1,5 m.
74-485	HV50 hood with magnet

Dimensions

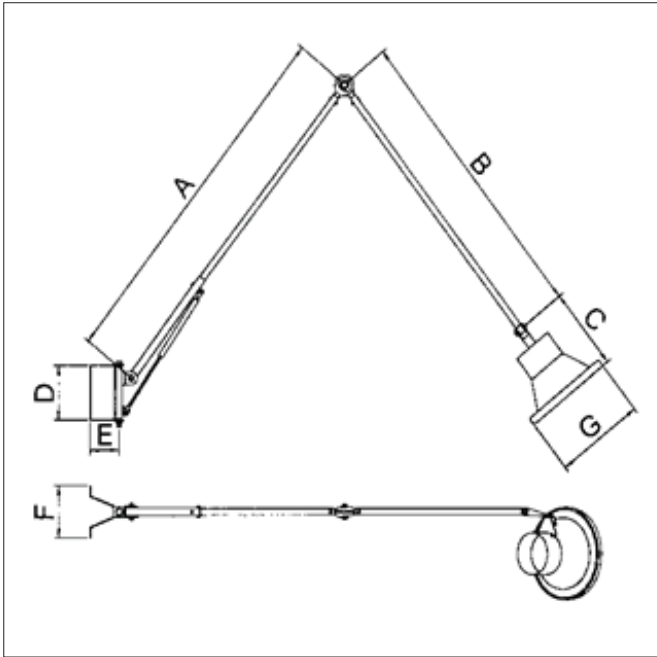

Dimensions for ASA-3

Arm-length	A	B	D	E	F
Arm 2,0 m	920 mm	680 mm	206 mm	120 mm	200 mm
Arm 3,0 m	1420 mm	1180 mm	206 mm	120 mm	200 mm
Arm 4,0 m	1870 mm	1710 mm	206 mm	120 mm	200 mm

Dimensions - Wall

